

## General Description

The NorthBridge Semiconductor A6PCUxx family are single chip multi-channel UARTs with an integrated PCI interface. The family includes 3 devices; the 8 channel A6PCU08, the 16 channel A6PCU16 and the 32 channel A6PCU32.

Each member of the family has independent, high performance UARTs with 128 byte transmit and receive FIFOs and selectable data rates up to 1Mbps. The FIFOs reduce the CPU overhead and maximize system bandwidth. Additionally each UART also has independent baud rate generators, character time out and interrupt processing.

In addition to increased performance and FIFO size, the A6PCUxx family also provides enhanced features including superior flow control as well as maintaining industry standard 16550 compatibility.

The NBS A6PCUxx family also features a 32 bit, 33MHz PCI bus for highly efficient system data transfer. The PCI bus is PCI 2.2 compliant.

A6PCUxx UART flow control and interrupt thresholds are fully programmable and readable. Transmit and Receive FIFO levels are also readable. These features allow for the creation of highly efficient and fast driver applications. The addition of software reset enables recovery from unforeseen error conditions allowing drivers to restart gracefully.

## Applications

- Multi-channel serial IO boards
- Industrial controllers
- FAX/MODEM concentrators
- Supervisory / maintenance terminals
- Universal Form Factor PCI Bus Add-in Card
- Remote Access Servers
- Network Management
- Factory Automation and Process Control
- Point-of-Sale Systems
- Multi-port RS-232/RS-422/RS-485 Cards

## Features

- Multiple, independent high performance UART channels
  - A6PCU08 – 8 UARTs
  - A6PCU16 – 16 UARTs
  - A6PCU32 – 32 UARTs
- Independent baud rate selection for each channel
- Baud Rates up to 1Mbps
- UARTs compatible with industry standard 16550 UART
- Deep 128 byte Transmit and Receive FIFOs for each channel
- 32/33 PCI 2.2 compliant target interface
- All Modem control functions available
- Prioritized interrupts
- DSR/DTR Hardware Flow control
- XON/XOFF Software Flow Control
- Global Interrupt Status and Readable FIFO Flags
- Programmable Transmit and Receive FIFO Flags and interrupts.
- Each UART has separate register set for independent control
- RS-485 Half Duplex Control
- Drivers/API for Windows and Linux

## Functional Block Diagram

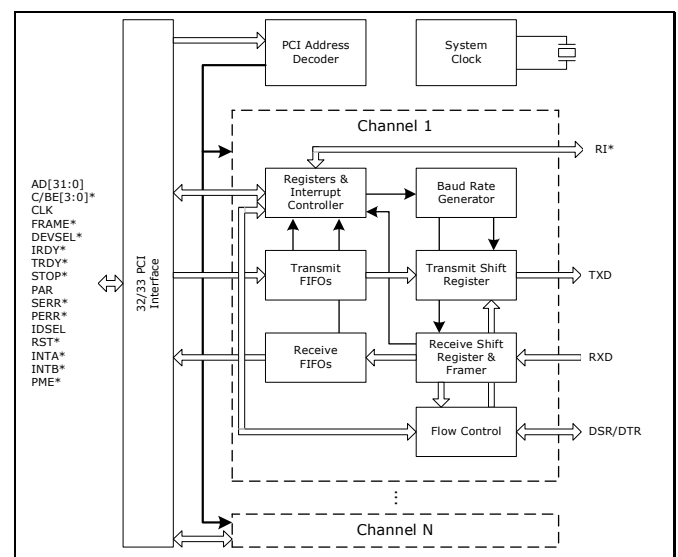

## Typical Application

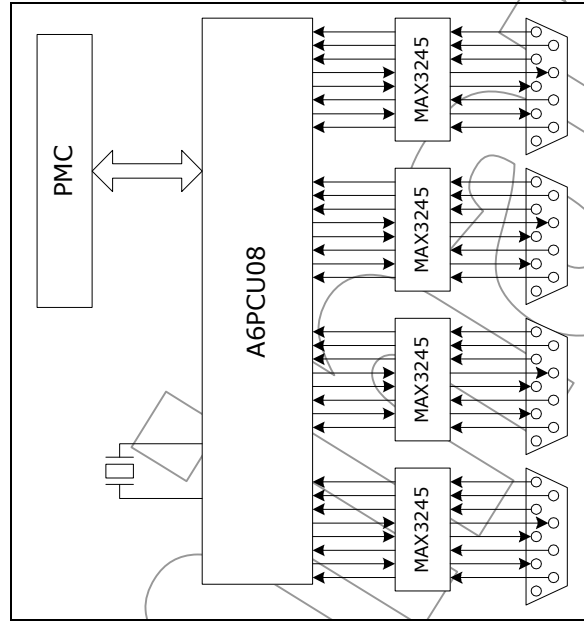

## Selection Guide

| Part #          | #Channels | Temp     | Package |
|-----------------|-----------|----------|---------|
| A6PCU08-PQ208C  | 8         | 0-70°C   | pq208   |
| A6PCU16-PQ208C  | 16        | 0-70°C   | pq208   |
| A6PCU32-PQ208C  | 32        | 0-70°C   | pq208   |
| A6PCU08-PQ208I  | 8         | -40-85°C | pq208   |
| A6PCU16-PQ208I  | 16        | -40-85°C | pq208   |
| A6PCU328-PQ208I | 32        | -40-85°C | pq208   |

## Customizations

NorthBridge Semiconductor is a distinctive manufacturer of electronic components. Due to our innovative process technology, NorthBridge Semiconductor can tailor many features and timing parameters to our customer's specifications in order to accommodate a wide variety of applications without incurring additional large costs. Traditional semiconductor manufacturers must anticipate all applications and situations, which

increases the die size (cost) and greatly escalating the complexity (and possibility of failures) of the devices. If your application does not fit the foreseen purposes, then additional external circuitry must be added, increasing costs.

By contrast, NorthBridge Semiconductor provides core functionalities and allows the customer to tweak the design to fit their needs. This means no wasted die space (lower cost); simpler, more reliable circuitry and fewer external support parts.